

Installation, Operation, & Maintenance Manual

**IMPORTANT!
DO NOT DESTROY**

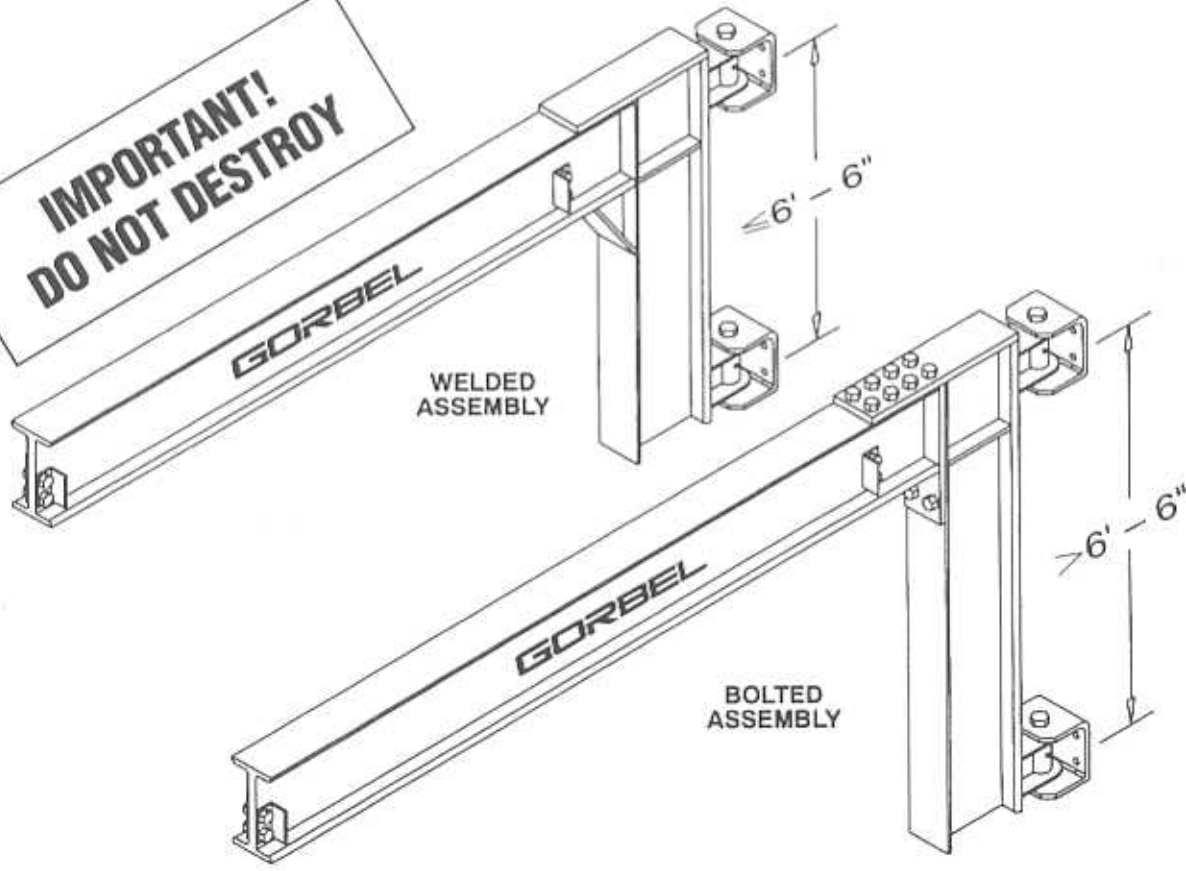

Wall Cantilever Jib Crane

Gorbel Dealer _____

Gorbel Customer Order No. _____

Date _____
Month Year

TABLE OF CONTENTS

Introduction	1
Installation	
Step 1 - Pre-Assembly	2-3
Step 2 - Boom/Mast Assembly Installation	4
Step 3 - Endstop/Tagline Installation & Accessories	5
Step 4 - Fabrication Information	6
Step 5 - Final Steps	7
Crane Operator Instructions	8
General Safety Suggestions	8
Warranty.....	9
Inspection and Maintenance Schedule	10

Questions? Concerns? Comments? Please call (800) 821-0086 (US and Canada) or (585) 924-6262 (outside US).

INTRODUCTION

Thank you for choosing a Gorbel® Wall Cantilever Jib Crane to solve your material handling needs. The innovative design and heavy-duty construction of Gorbel® Jib Cranes provide a superior quality product and offer years of long term value. The hoist and trolley weight allowance is 15% of the crane capacity (for example, a crane rated for 1000 pounds allows for a 1000-pound live load, plus 150 pounds for the weight of the hoist and trolley). There is also an allowance of 25% of the crane capacity for impact caused by the hoist use. Gorbel® Jib Cranes will provide many years of dependable service by following the installation and maintenance procedures described herein.

Dimensions contained in this installation manual are for reference only and may differ for your particular application.

Normal safety precautions: These include, but are not limited to:

- Checking for obstructions in crane rotation
- Checking that all bolts are tight and have lockwashers
- Making sure that endstops are in place

For additional safety precautions see page 8.

WARNING

Only competent erection personnel familiar with standard fabrication practices should be employed to assemble these cranes because of the necessity of properly interpreting these instructions. Gorbel is not responsible for the quality of workmanship employed in the installation of a crane according to these instructions. Contact Gorbel, Inc., at 600 Fishers Run, P.O. Box 593, Fishers, New York 14453-0593, 1-800-821-0086, for additional information if necessary.

WARNING

Equipment described herein is not designed for, and should not be used for, lifting, supporting or transporting humans. Failure to comply with any one of the limitations noted herein can result in serious bodily injury and/or property damage. Check Federal, State and Local regulations for any additional requirements.

WARNING

Reference the American Institute of Steel Construction (AISC) Manual of Steel Construction (9th edition), Part 5, Specification for Structural Joints using ASTM A325 or A490 Bolts (Section 8.d.2) for proper procedures to follow when using any torque tightening method.

INSTALLATION

STEP 1 - PRE-ASSEMBLY

➔ **TIP:** Packing list can be found in plastic pocket inside hardware box.

- 1.1 Read entire manual **before** beginning installation of crane.
- 1.2 Check packing list to ensure no parts have been lost prior to initializing assembly of crane.
- 1.3 Tools and materials (by others) often needed to assemble crane are as follows:
 - Torque wrench
 - Leveling tools and plumb bob
 - Hand tools
 - Lifting device to lift heavy masts and booms
 - Steel shims
 - Mounting hardware (grade 5 bolts or better)

- 1.4 Determine:
 - Thrust and pull (**diagram 1A** and **chart 1B**, page 3).

WARNING

Consult a qualified structural engineer to determine if your support structure is adequate to support the thrust and pull of your crane

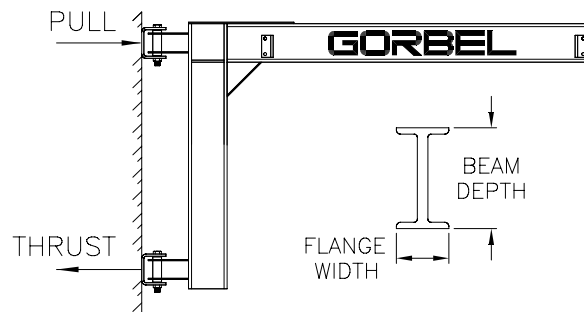

Diagram 1A. Thrust and pull definition.

- Bracket centers (**chart 1B**, page 3).
- Bolt pattern and dimensions (**diagrams 1B** and **1C**, and **chart 1A**).

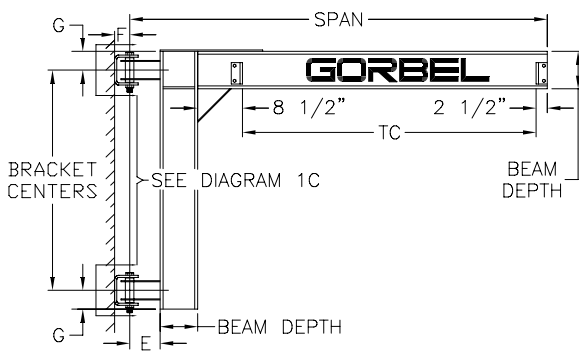

Diagram 1B.

Bolt Pattern	E	F	G	Hole Dia.	Bolt Dia.	Bracket Thickness
WC-B1	5"	3-1/2"	6"	11/16"	5/8"	1/2"
WC-B2	5"	4"	6"	13/16"	3/4"	5/8"
WC-B3	5"	4"	6"	13/16"	3/4"	3/4"
WC-B5	7"	6"	9"	1-5/16"	1-1/4"	1"

All dimensions shown in inches.

Chart 1A.

TC (trolley coverage (distance between endstops))
 = Span - (Beam Depth + E + 11")

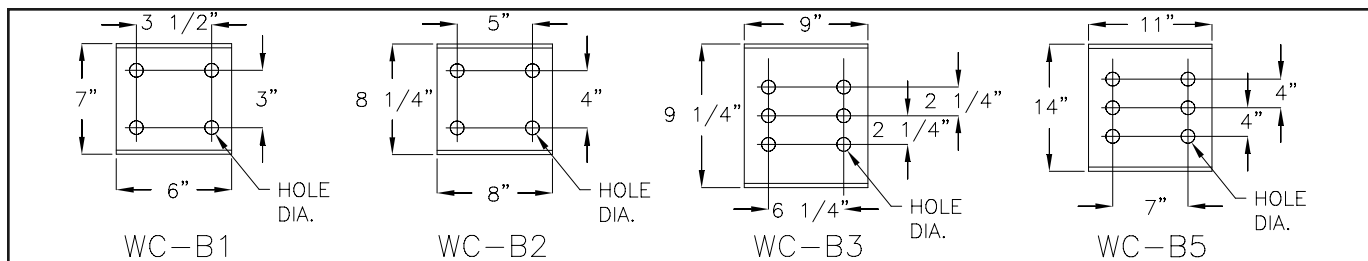

Diagram 1C.

STEP 1 - PRE-ASSEMBLY (CONTINUED)

Capacity (tons)	Span	Bracket Type	**Bracket Centers	Beam Depth	Flange Width	S/W Beam Boom Length	S/W Beam Mast Length	Connection Plate Type (see pg. 6)	Hole Set Type (pg. 7)	Thrust & Pull
1/4	8'	WC-B1	3' 0"	6"	3-3/8"	7' 1"	4' 0"	A	I	1,767 #
	10'		3' 0"	6"	3-3/8"	9' 0"	4' 0"	A	I	2,308 #
	12'		3' 0"	6"	3-3/8"	11' 1"	4' 0"	A	I	2,867 #
	*14'		3' 0"	8"	5-1/4"	13' 0"	4' 0"	B	I	3,621 #
	*16'		3' 0"	8"	5-1/4"	14' 11"	4' 0"	C	I	4,268 #
	*18'		4' 0"	8"	5-1/4"	16' 11"	5' 0"	C	I	3,704 #
20'	4' 0"	10"	4-5/8"	18' 9"	5' 0"	D	II	4,595 #		
1/2	*8'	WC-B1	3' 0"	8"	5-1/4"	7' 0"	4' 0"	B	I	3,459 #
	*10'		3' 0"	8"	5-1/4"	9' 0"	4' 0"	B	I	4,500 #
	*12'		3' 0"	8"	5-1/4"	11' 0"	4' 0"	B	I	5,565 #
	*14'		4' 0"	8"	5-1/4"	12' 11"	5' 0"	C	I	4,991 #
	16'		4' 0"	10"	4-5/8"	14' 9"	5' 0"	D	II	6,063 #
	18'		4' 0"	10"	4-5/8"	16' 9"	5' 0"	D	II	6,979 #
20'	6' 0"	12"	5"	18' 7"	7' 0"	E	II	5,493 #		
1	*8'	WC-B1	4' 0"	8"	5-1/4"	6' 11"	5' 0"	C	I	5,044 #
	10'		5' 0"	10"	4-5/8"	8' 9"	6' 0"	D	II	5,294 #
	12'		5' 0"	10"	4-5/8"	10' 9"	6' 0"	D	II	6,526 #
	14'		5' 0"	10"	4-5/8"	12' 9"	6' 0"	D	II	7,778 #
	16'		6' 0"	12"	5"	14' 7"	7' 0"	E	II	7,678 #
	*18'		6' 0"	16"	7"	16' 4"	7' 0"	F	II	9,148 #
*20'	6' 0"	16"	7"	18' 4"	7' 0"	F	II	10,367 #		
1-1/2	8'	WC-B2	3' 0"	10"	4-5/8"	6' 9"	4' 0"	D	I	10,071 #
	10'		3' 0"	10"	4-5/8"	8' 9"	4' 0"	D	I	13,023 #
	12'		4' 0"	12"	5"	10' 7"	5' 0"	E	I	12,122 #
	14'		4' 0"	12"	5"	12' 7"	5' 0"	E	I	14,429 #
	16'		5' 0"	12"	5"	14' 7"	6' 0"	E	I	13,414 #
	*18'		6' 0"	18"	7-1/2"	16' 1"	7' 0"	G	II	13,250 #
*20'	6' 0"	18"	7-1/2"	18' 1"	7' 0"	G	II	14,967 #		
2	8'	WC-B2	4' 0"	12"	5"	6' 7"	5' 0"	E	II	10,054 #
	10'		4' 0"	12"	5"	8' 7"	5' 0"	E	II	12,998 #
	*12'		4' 6"	16"	7"	10' 4"	5' 6"	F	II	14,409 #
	*14'		5' 0"	16"	7"	12' 4"	6' 0"	F	II	15,442 #
	*16'		6' 0"	18"	7-1/2"	14' 1"	7' 0"	G	II	15,067 #
	*18'		6' 6"	18"	7-1/2"	16' 1"	7' 6"	H	II	15,892 #
*20'	7' 6"	21"	8-1/4"	17' 10"	8' 6"	J	II	15,840 #		
3	*8'	WC-B3	4' 0"	16"	7"	6' 4"	5' 0"	F	II	15,060 #
	*10'		4' 6"	16"	7"	8' 4"	5' 6"	F	II	17,300 #
	*12'		5' 6"	16"	7"	10' 4"	6' 6"	F	II	17,389 #
	*14'		6' 0"	18"	7-1/2"	12' 1"	7' 0"	G	II	19,017 #
	*16'		7' 6"	18"	7-1/2"	14' 1"	8' 6"	H	II	17,653 #
	*18'		8' 6"	21"	8-1/4"	15' 10"	9' 6"	J	II	17,982 #
*20'	9' 6"	21"	8-1/4"	17' 7"	10' 6"	J	II	18,105 #		
5	*8'	WC-B5	6' 6"	18"	7-1/2"	5' 11"	8' 0"	H		15,323 #
	*10'		6' 6"	18"	7-1/2"	7' 11"	8' 0"	H		19,770 #
	*12'		6' 6"	21"	8-1/4"	9' 8"	8' 0"	J		24,379 #
	*14'		7' 6"	21"	8-1/4"	11' 8"	9' 0"	J		25,077 #
	*16'		9' 6"	21"	8-1/4"	13' 8"	11' 0"	J		22,941 #
	*18'		9' 6"	24"	9"	15' 5"	11' 0"	K		26,485 #
*20'	9' 6"	24"	9"	17' 5"	11' 0"	K		29,769 #		

* located in front of Span means that a W-Beam is used instead of an S-Beam.

** Custom bracket centers available, consult Customer Service.

Chart 1B.

STEP 2 - BOOM/MAST ASSEMBLY INSTALLATION

➔ **TIP:** Upper and lower formed channel (brackets) are identical.

STOP!

Do not proceed if your support structure does not meet the loading requirements identified in **Step 1.4**.

- 2.1 Determine position of **upper-formed** channel bracket on support structure. Drill bolt holes (see **chart 1A**, page 2, for bolt diameter) and bolt to support structure.
- 2.2 Determine position of lower formed channel bracket by measuring distance between bracket centers; clamp bracket to support structure. Align brackets by dropping plumb bob (by others) through pivot holes and making sure string is centered in pivot holes (**diagram 2A**). Shim, if necessary, between mounting surface and formed channel brackets (shims by others).
- 2.3 Drill bolt holes for **lower** bracket (see **chart 1A**, page 2, for bolt diameter) and bolt to support structure. Do not torque bolts until boom has been leveled (Step 2.6).
- 2.4 **If you have a jib with a bolted connection**, bolt boom to mast using all hardware provided (**diagram 2B**). Torque nuts (**chart 2A**). (Check packing list for exact quantity of bolts required.)

Diagram 2A. Plumbing formed channel brackets.

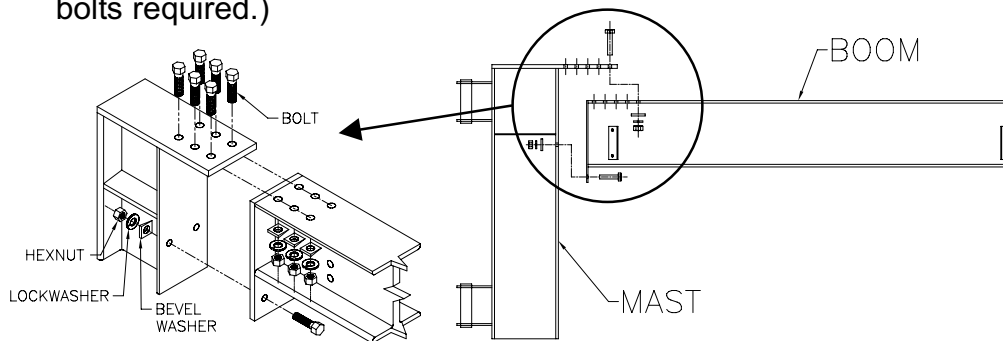

Diagram 2B. Bolting boom to mast.

Bolt Dia.	Torque
1/2"	50 ft.-lbs.
5/8"	95 ft.-lbs.
3/4"	175 ft.-lbs.
7/8"	300 ft.-lbs.
1"	450 ft.-lbs.

Chart 2A. Torque Ratings.

- 2.5 Attach boom/mast assembly to formed channel using hardware provided (**diagram 2C**). Be sure that thrust washers are in position. Tighten nuts on pivot bolt until lockwashers are compressed, being sure boom rotates freely.
- 2.6 **For bolted connection:** level boom to a point of L/300 of span above level. Shim, if necessary, between mast and back of boom plate (shims by others).
- 2.7 Tighten mounting bolts (grade 5 or better) to manufacturer's specifications.

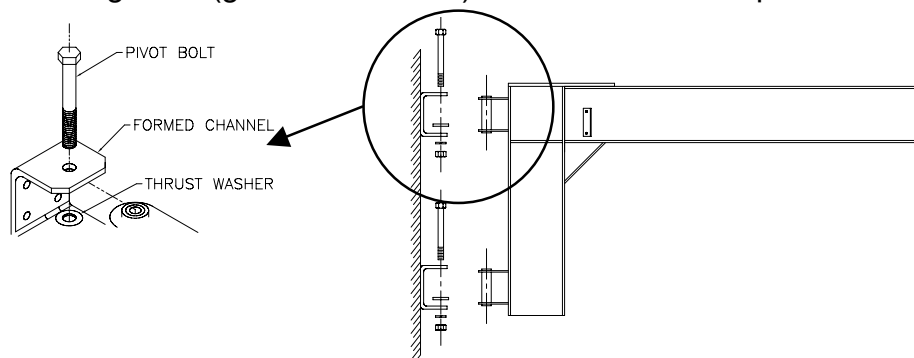

Diagram 2C. Attaching boom/mast assembly to formed channel.

STEP 3 - ENDSTOP/TAGLINE INSTALLATION & ACCESSORIES

WARNING

Must install either endstops or tagline assembly.
(Tagline doubles as endstop.)

3.1 Endstop

- Bolt endstops to end of boom closest to mast (**diagram 3A**).
- Roll hoist trolley (by others) into place.
- Bolt remaining endstops into place at the front of boom (**diagram 3A**).
- Torque nuts (refer to **chart 2A**, page 4, for proper torque rating).

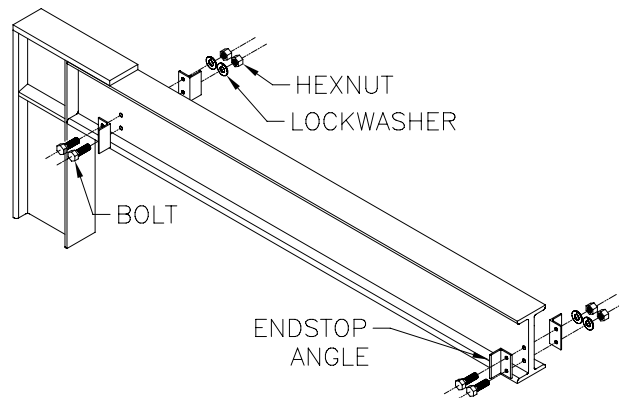

Diagram 3A. Endstop installation.

3.2 Tagline Assembly

- Bolt tagline bracket and an endstop angle to end of boom closest to mast (**diagram 3B**).
- Roll hoist trolley (by others) into place.
- Bolt remaining tagline bracket and endstop angle into place at the front of the boom (**diagram 3B**). Torque nuts (refer to **chart 2A**, page 4, for proper torque rating).
- Bolt eyebolt to the tagline brackets. Be sure the eyes of the eyebolts are oriented toward each other.
- Run wire rope between eyebolts and clamp to form a loop at each end.
- Tighten eyebolts so wire rope is taut.
- Add "S" hooks to wire rope and squeeze closed the top of the "S" hook.
- Space "S" hooks evenly along wire rope and place round power/air cable through bottom loop of the "S" hooks.
- Squeeze bottom of "S" hook to grip wire, or tape wire in place.

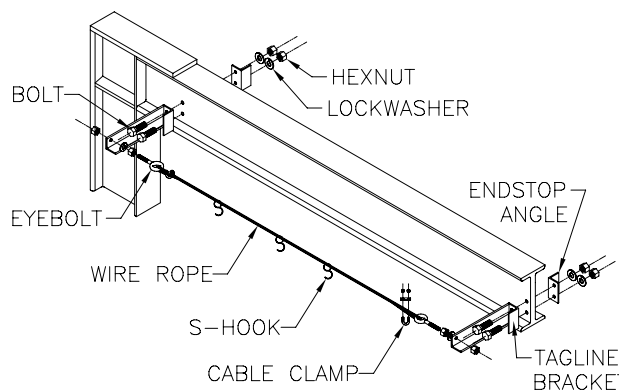

Diagram 3B Tagline assembly installation.

Rotation Stops (Optional): Both Formed Channels

- Swing boom to the farthest position of use on one side.
- Place rotation stop on upper formed channel with its edge against the pivot assembly.
- Weld stop to formed channel using E70xx electrodes, per AWS D1.1 specifications.
- Repeat welding procedure for lower formed channel.
- Repeat Steps A-D for opposite direction.

Other Options (Consult Gorbel® Representative)

- Flat Wire Conductor Cable
- Flat Wire Cord Grip Connectors
- Wire Rope Trolleys for Flat or Round Cable
- Positional Lock Devices

WARNING

Rotation Stops are meant to limit rotation, not stop rotation.

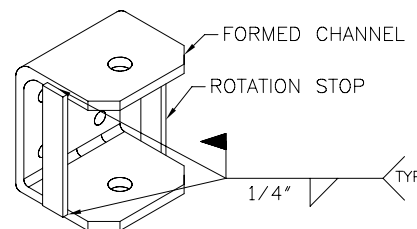
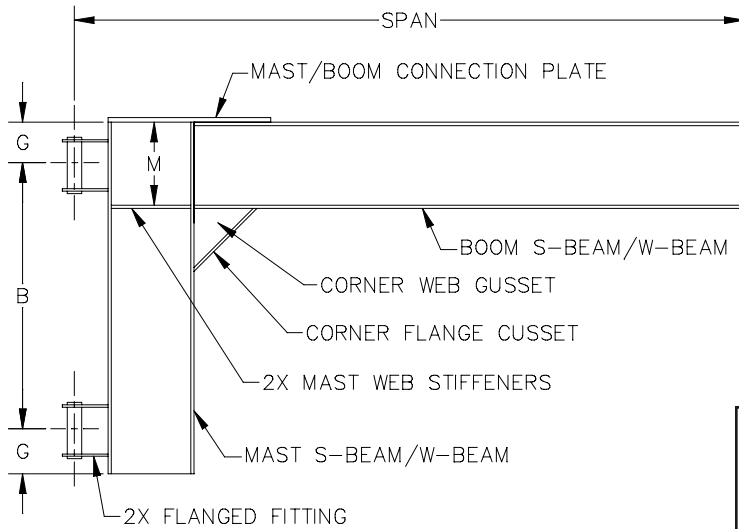

Diagram 3C. Welding rotation stops.

STEP 4 - FABRICATION INFORMATION

TIP: For use with Gorbel® supplied Wall Cantilever fittings only.



NOTE: All mast/boom connections, corner web gusset, corner flange gusset, and mast web stiffeners are welded solid to develop full strength with 1/4" fillet weld using E70xx electrodes.

Bracket Type	Boom Length =	Mast Length =
WC-B1	Span - (Mast Width + 5)	Bracket Centers + 12
WC-B2	Span - (Mast Width + 5)	Bracket Centers + 12
WC-B3	Span - (Mast Width + 5)	Bracket Centers + 12
WC-B5	Span - (Mast Width + 7)	Bracket Centers + 18

Type	Plate Size	Type	Plate Size
A	3/8 x 4 x 9 3/4 lg., HRS	F	3/4 x 6 x 33 lg., HRS
B	3/8 x 4 x 13 3/8 lg., HRS	G	3/4 x 7 x 40 lg., HRS
C	1/2 x 5 x 14 7/8 lg., HRS	H	1 x 6 1/2 x 34 lg., HRS
D	1/2 x 5 x 19 7/8 lg., HRS	J	1 x 9 x 37 lg., HRS
E	1/2 x 5 1/2 x 23 7/8 lg., HRS	K	1 1/2 x 9 1/2 x 43 lg., HRS

S/W Beam	THK	X	Y	Z	Q	M	ZZ1	ZZ2
S6 x 12.5	1/4	5 5/16	1 1/2	9/16	3	5 3/4	1/4	1/4
W8 x 18	1/4	7 7/16	1 1/2	5/8	4	7 3/4	3/8	3/8
S10 x 25.4	1/4	9 1/8	2	3/8	4 1/2	9 3/4	3/8	3/8
S12 x 31.8	1/4	11 1/8	2 1/4	7/8	5	11 3/4	9/16	7/16
W16 x 45	1/4	14 1/8	2 1/2	1	5 1/2	14 3/4	5/8	3/8
W18 x 50	1/4	17 3/16	2 3/4	1 1/16	6	17 3/4	5/8	5/8
W21 x 62	1/2	19 1/2	4	0	0	20 3/4	1 1/8	1 1/8
W24 x 84	1/2	22 7/16	4 1/4	0	0	23 7/8	11/16	11/16

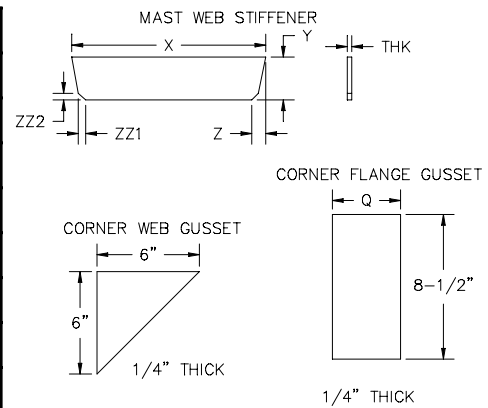

ALL DIMENSIONS ON THIS PAGE ARE SHOWN IN INCHES

Hole Set Type						
Bracket Type	WC-B1		WC-B2		WC-B3	
Direction of Dimension	↔	↕	↔	↕	↔	↕
Type I	2 1/4	2	2 3/4	3		
Type II	2 3/4	6 1/2	3	7 3/4	3 1/4	8 3/4
Bolt Size (used with bevel washer, lockwasher and nut.)	5/8" - 11 x 3 1/4 lg. A325		5/8" - 11 x 3 1/4 lg. A325		3/4" - 10 x 3 1/2 lg. A325	

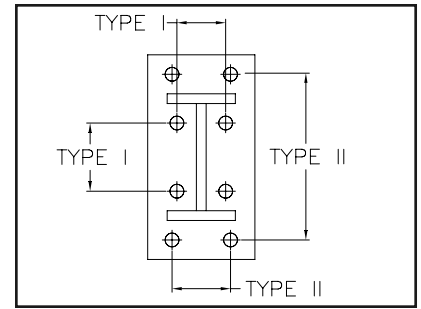

ALL DIMENSIONS ON THIS PAGE ARE SHOWN IN INCHES

STEP 5 - FINAL STEPS

► **TIP:** Do not throw away this manual: the maintenance schedule is on the back cover.

- 5.1 Check to make sure all bolts are tight and lockwashers are compressed.
- 5.2 Grease all fittings (use Lubriplate #630-AA or equivalent).
- 5.3 If necessary, touch up crane with paint provided.
- 5.4 Keep Packing List, Installation Manual, General Arrangement Drawing and any other inserts filed together in safe place.

CRANE OPERATOR INSTRUCTIONS

Overhead cranes and jib cranes generally handle materials over working areas where there are personnel. Therefore, it is important for the Crane Operator to be instructed in the use of the crane and to understand the severe consequences of careless operation. It is not intended that these suggestions take precedence over existing plant safety rules and regulations or OSHA regulations. However, a thorough study of the following information should provide a better understanding of safe operation and afford a greater margin of safety for people and machinery on the plant floor. It must be recognized that these are suggestions for the Crane Operator's use. It is the responsibility of the owner to make personnel aware of all federal, state and local rules and codes, and to make certain operators are properly trained.

Qualifications

Crane operation, to be safe and efficient, requires skill: the exercise of extreme care and good judgment, alertness and concentration, and rigid adherence to proven safety rules and practices as outlined in applicable and current ANSI and OSHA safety standards. In general practice, no person should be permitted to operate a crane:

- Who cannot speak the appropriate language or read and understand the printed instructions.
- Who is not of legal age to operate this type of equipment.
- Whose hearing or eyesight is impaired (unless suitably corrected with good depth perception).
- Who may be suffering from heart or other ailments which might interfere with the operator's safe performance.
- Unless the operator has carefully read and studied this operation manual.
- Unless the operator has been properly instructed.
- Unless the operator has demonstrated his instructions through practical operation.
- Unless the operator is familiar with hitching equipment and safe hitching equipment practices.

Handling the Jib Boom Motion

Before using the boom of the jib crane, the operator should be sure the hook is high enough to clear any obstruction. Before a load is handled by the crane, the jib boom should be brought into position so that it is directly over the load. Start the jib boom slowly and bring it up to speed gradually. Approaching the place where it is desired to stop the jib, reduce the boom speed.

Handling the Trolley Motion

Before a load is handled, the hoist should be positioned directly over the load that is to be handled. When the slack is taken out of the slings, if the hoist is not directly over the load, bring it directly over the load before hoisting is continued. Failure to center the hoist over the load may cause the load to swing upon lifting. Always start the trolley motion slowly and reduce the trolley speed gradually.

Handling the Hoist Motion

Refer to the lifting (hoist) equipment's operating instructions.

GENERAL SUGGESTIONS

Know Your Crane

Crane operators should be familiar with the principal parts of a crane and have a thorough knowledge of crane control functions and movements. The crane operator should be required to know the location and proper operation of the main conductor disconnecting means for all power to the attachments on the crane.

Responsibility

Each crane operator should be held directly responsible for the safe operation of the crane. Whenever there is any doubt as to SAFETY, the crane operator should stop the crane and refuse to handle loads until: (1) safety has been assured or (2) the operator has been ordered to proceed by the supervisor, who then assumes all responsibility for the SAFETY of the lift.

Do not permit **ANYONE** to ride on the hook or a load.

Inspection

Test the crane movement and any attachments on the crane at the beginning of each shift. Whenever the operator finds anything wrong or apparently wrong, the problem should be reported immediately to the proper supervisor and appropriate corrective action taken.

Operating Suggestions

One measure of a good crane operator is the smoothness of the crane operation. The good crane operator should know and follow these proven suggestions for safe, efficient crane handling.

1. The crane should be moved smoothly and gradually to avoid abrupt, jerky movements of the load. Slack must be removed from the sling and hoisting ropes before the load is lifted.
2. Center the crane over the load before starting the hoist to avoid swinging the load as the lift is started. Loads should not be swung by the crane to reach areas not under the crane.
3. Crane-hoisting ropes should be kept vertical. Cranes shall not be used for side pulls.
4. Be sure everyone in the immediate area is clear of the load and aware that a load is being moved.
5. Do not make lifts beyond the rated load capacity of the crane, sling chains, rope slings, etc.
6. Make certain that before moving the load, load slings, load chains, or other lifting devices are fully seated in the saddle of the hook with hook latch closed (if equipped with hook latch).
7. Check to be sure that the load and/or bottom block is lifted high enough to clear all obstructions when moving boom or trolley.
8. At no time should a load be left suspended from the crane unless the operator has the push button with the power on, and under this condition keep the load as close as possible to the floor to minimize the possibility of an injury if the load should drop. When the crane is holding a load, the crane operator should remain at the push button.
9. Do not lift loads with sling hooks hanging loose. If all sling hooks are not needed, they should be properly stored, or use a different sling.
10. All slings or cables should be removed from the crane hooks when not in use (dangling cables or hooks hung in sling rings can inadvertently snag other objects when the crane is moving).
11. Operators shall not carry loads and/or empty bottom blocks over personnel. Particular additional caution should be practiced when using magnet or vacuum devices. Loads, or parts of loads, held magnetically could drop. Failure of power to magnets or vacuum devices can result in dropping the load. Extra precaution should be exercised when handling molten metal in the proximity of personnel.
12. Whenever the operator leaves the crane the following procedure should be followed:
 - Raise all hooks to an intermediate position.
 - Spot the crane at an approved designated location.
 - Place all controls in the "off" position.
 - Open the main switch to the "off" position.
 - Make visual check before leaving the crane.
13. In case of emergency or during inspection, repairing, cleaning or lubrication, a warning sign or signal should be displayed and the main switch should be locked in the "off" position. This should be done whether the work is being done by the crane operator or by others.
14. Contact with rotation stops or trolley end stops shall be made with extreme caution. The operator should do so with particular care for the safety of persons below the crane, and only after making certain that any persons on the other cranes are aware of what is being done.
15. **ANY SAFETY FEATURES AND MECHANISMS BUILT-IN OR OTHERWISE PROVIDED WITH THE CRANE BY GORBEL ARE REQUIRED FOR THE SAFE OPERATION OF THE CRANE. DO NOT, UNDER ANY CIRCUMSTANCES, REMOVE OR OTHERWISE IMPAIR OR DISABLE THE PROPER FUNCTIONING OF ANY CRANE SAFETY MECHANISMS OR FEATURES BUILT-IN OR OTHERWISE PROVIDED BY GORBEL FOR SAFE OPERATION OF THE CRANE. ANY REMOVAL, IMPAIRMENT OR DISABLING OF ANY SUCH SAFETY MECHANISMS OR FEATURES OR OTHER USE OR OPERATION OF THE CRANE WITHOUT THE COMPLETE AND PROPER FUNCTIONING OF ANY SUCH SAFETY MECHANISMS OR FEATURES AUTOMATICALLY AND IMMEDIATELY VOIDS ANY AND ALL EXPRESS AND IMPLIED WARRANTIES OF ANY KIND OR NATURE.**

LIMITED WARRANTY

It is agreed that the equipment purchased hereunder is subject to the following LIMITED warranty and no other. Gorbel Incorporated ("Gorbel"), warrants the manual push-pull Work Station Cranes, Jib Crane, and Gantry Crane products to be free from defects in material or workmanship for a period of five years or 10,000 hours use from date of shipment. Gorbel warrants the Motorized Work Station Cranes and Jib Crane products to be free from defects in material or workmanship for a period of two years or 4,000 hours use from the date of shipment. Gorbel warrants the G-Force® and Easy Arm™ products to be free from defects in material or workmanship for a period of one year or 2,000 hours use from the date of shipment. This warranty shall not cover failure or defective operation caused by operation in excess of recommended capacities, misuses, negligence or accident, and alteration or repair not authorized by Gorbel. No system shall be modified after manufacture without the written authorization of Gorbel, Inc. Any field modification made to the system without the written authorization of Gorbel, Inc. shall void Gorbel's warranty obligation. OTHER THAN AS SET FORTH HEREIN, NO OTHER EXPRESS WARRANTIES, AND NO IMPLIED WARRANTIES, ORAL OR WRITTEN, INCLUDING BUT NOT LIMITED TO THE WARRANTIES OF MERCHANTABILITY OR FITNESS FOR A PARTICULAR PURPOSE, ARE MADE BY GORBEL WITH RESPECT TO ITS PRODUCTS AND ALL SUCH WARRANTIES ARE HEREBY SPECIFICALLY DISCLAIMED. GORBEL SHALL NOT BE LIABLE UNDER ANY CIRCUMSTANCES FOR ANY INCIDENTAL, SPECIAL AND/OR CONSEQUENTIAL DAMAGES WHATSOEVER, WHETHER OR NOT FORESEEABLE, INCLUDING BUT NOT LIMITED TO DAMAGES FOR LOST PROFITS AND ALL SUCH INCIDENTAL, SPECIAL AND/OR CONSEQUENTIAL DAMAGES ARE HEREBY ALSO SPECIFICALLY DISCLAIMED. Gorbel's obligation and Purchaser's or end user's sole remedy under this warranty is limited to the replacement or repair of Gorbel's products at the factory, or at the discretion of Gorbel, at a location designated by Gorbel. Purchaser or end user shall be solely responsible for all freight and transportation costs incurred in connection with any warranty work provided by Gorbel hereunder. Gorbel will not be liable for any loss, injury or damage to persons or property, nor for damages of any kind resulting from failure or defective operation of any materials or equipment furnished hereunder. Components and accessories not manufactured by Gorbel are not included in this warranty. Purchaser's or end user's remedy for components and accessories not manufactured by Gorbel is limited to and determined by the terms and conditions of the warranty provided by the respective manufacturers of such components and accessories.

A) DISCLAIMER OF IMPLIED WARRANTY OF MERCHANTABILITY

Gorbel and Purchaser agree that the implied warranty of merchantability is excluded from this transaction and shall not apply to the goods involved in this transaction.

B) DISCLAIMER OF IMPLIED WARRANTY OF FITNESS FOR PARTICULAR PURPOSE

Gorbel and Purchaser agree that the implied warranty of fitness for particular purpose is excluded from this transaction and shall not apply to the goods involved in this transaction.

C) DISCLAIMER OF EXPRESS WARRANTY

Gorbel's agents, or dealer's agents, or distributor's agents may have made oral statements about the machinery and equipment described in this transaction. Such statements do not constitute warranties, and Purchaser agrees not to rely on such statements. Purchaser also agrees that such statements are not part of this transaction.

D) DISCLAIMER OF SPECIAL, INCIDENTAL AND CONSEQUENTIAL DAMAGES

Gorbel and Purchaser agree that any claim made by Purchaser which is inconsistent with Gorbel's obligations and the warranty remedies provided with Gorbel's products, and in particular, special, incidental and consequential damages, are expressly excluded.

E) DEALER OR DISTRIBUTOR NOT AN AGENT

Gorbel and Purchaser agree that Purchaser has been put on notice that dealer or distributor is not Gorbel's agent in any respect for any reason. Gorbel and Purchaser also agree that Purchaser has been put on notice that dealer or distributor is not authorized to incur any obligations or to make any representations or warranties on Gorbel's behalf other than those specifically set forth in Gorbel's warranty provided in connection with its product.

F) MERGER

This warranty agreement constitutes a final and complete written expression of all the terms and conditions of this warranty and is a complete and exclusive statement of those terms.

G) PAINTING

Every crane (excluding components) receives a quality paint job before leaving the factory. Unfortunately, no paint will protect against the abuses received during the transportation process via common carrier. We have included at least one (1) twelve ounce spray can for touchup with each crane ordered (unless special paint was specified). If additional paint is required, contact a Gorbel® Customer Service Representative at 1-800-821-0086 or 1-585-924-6262.

Title and Ownership:

Title to the machinery and equipment described in the foregoing proposal shall remain with the Gorbel and shall not pass to the Purchaser until the full amount herein agreed to be paid has been fully paid in cash.

Claims and Damages:

Unless expressly stated in writing, goods and equipment shall be at Purchaser's risk on and after Seller's delivery in good shipping order to the Carrier. Gorbel shall in no event be held responsible for materials furnished or work performed by any person other than it or its authorized representative or agent.

Cancellations:

If it becomes necessary for the purchaser to cancel this order wholly or in part, he shall at once so advise Gorbel in writing. Upon receipt of such written notice all work will stop immediately. If the order entails only stock items, a flat restocking charge of 15% of the purchase price will become due and payable by Purchaser to Gorbel. Items purchased specifically for the canceled order shall be charged for in accordance with the cancellation charges of our supplier plus 15% for handling in our factory. The cost of material and/or labor expended in general fabrication for the order shall be charged for on the basis of total costs to Gorbel up to the time of cancellation plus 15%.

Returns:

No equipment, materials or parts may be returned to Gorbel without express permission in writing to do so.

Extra Charge Delay: If Purchaser delays or interrupts progress of Seller's performance, or causes changes to be made, Purchaser agrees to reimburse Gorbel for expense, if any, incident to such delay.

Changes and Alterations:

Gorbel reserves the right to make changes in the details of construction of the equipment, as in its judgment, will be in the interest of the Purchaser; will make any changes in or additions to the equipment which may be agreed upon in writing by the Purchaser; and Gorbel is not obligated to make such changes in products previously sold any customer.

Third Party Action:

Should Gorbel have to resort to third party action to collect any amount due after there (30) days from date of invoice, the Purchaser agrees to pay collection costs, reasonable attorney's fees, court costs and legal interest.

OSHA Responsibilities:

Gorbel agrees to fully cooperate with Purchaser in the design, manufacture or procurement of safety features or devices that comply with OSHA regulations. In the event additional equipment or labor shall be furnished by Gorbel, it will be at prices and standard rates then in effect, or as may be mutually agreed upon at the time of the additional installation.

Equal Employment Opportunity:

Gorbel agrees to take affirmative action to ensure equal employment opportunity for all job applicants and employees without regard to race, color, age, religion, sex, national origin, handicap, veteran, or marital status. Gorbel agrees to maintain non-segregated work facilities and comply to rules and regulations of the Secretary of Labor or as otherwise provided by law or Executive Order.

INSPECTION AND MAINTENANCE

GORBEL® WALL CANTILEVER JIB CRANE INSPECTION AND MAINTENANCE SCHEDULE			
ITEM	COMPONENT	MAINTENANCE	FREQUENCY*
1	Mounting Bolts	Check that lockwashers are compressed and nuts tightened to manufacturers specifications.	Every 500 hours or 3 months
2	Pivot Assemblies	Check that lockwashers are compressed. Check for wear on thrust washers. Grease fittings (use Lubriplate #630-AA or equivalent).	Every 1000 hours or 6 months
3	Endstops or Tagline Assemblies	Check that lockwashers are compressed and nuts are tightened to torque specifications (chart 2A , page 4).	Every 500 hours or 3 months
4	Bolted Connection	Check that lockwashers are compressed and nuts are tightened to torque specifications (chart 2A , page 4).	Every 500 hours or 3 months
5	Accessory Items	Conduct a visual inspection of all accessory items.	Every 1000 hours or 6 months
6	Gorbel® Crane	Conduct a visual inspection of wall cantilever jib crane weldment.	Every 1000 hours or 6 months

*Federal, state and local codes may require inspection and maintenance checks more often. Please check the federal, state and local code manuals in your area.

WARNING

Any changes in rolling effort or unusual noises must be immediately identified and corrected.

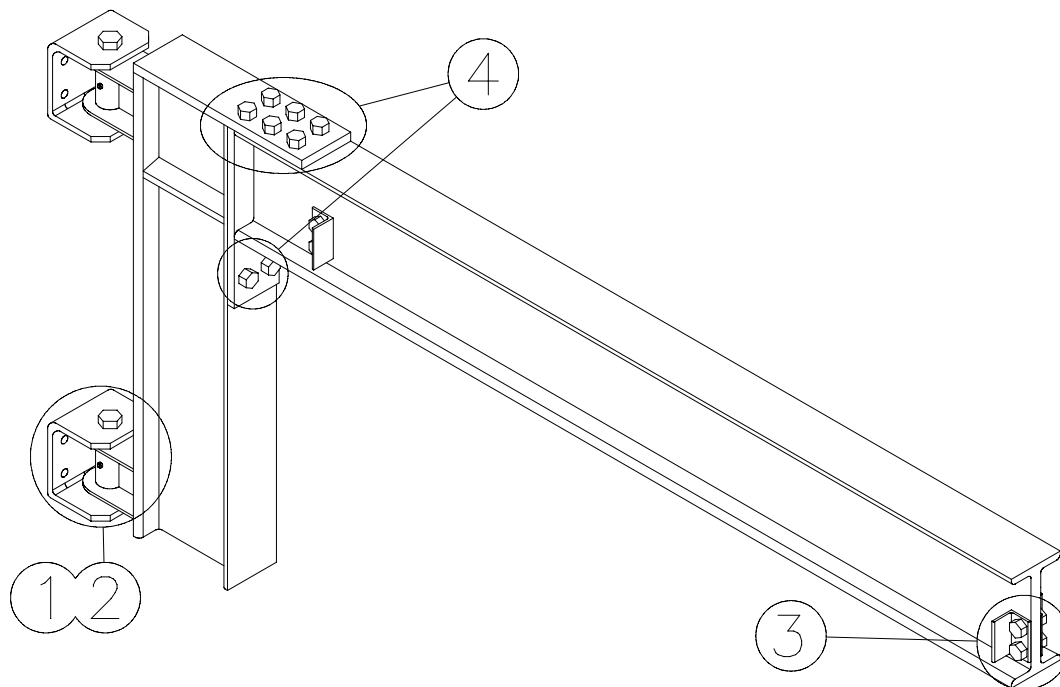

GORBEL®

600 Fishers Run, P.O. Box 593
 Fishers, NY 14453-0593
 Phone: (800) 821-0086
 Fax: (800) 828-1808
 E-Mail: info@gorbel.com
<http://www.gorbel.com>

© 2007 Gorbel Inc.
 All Rights Reserved