

Installation, Operation, & Maintenance Manual

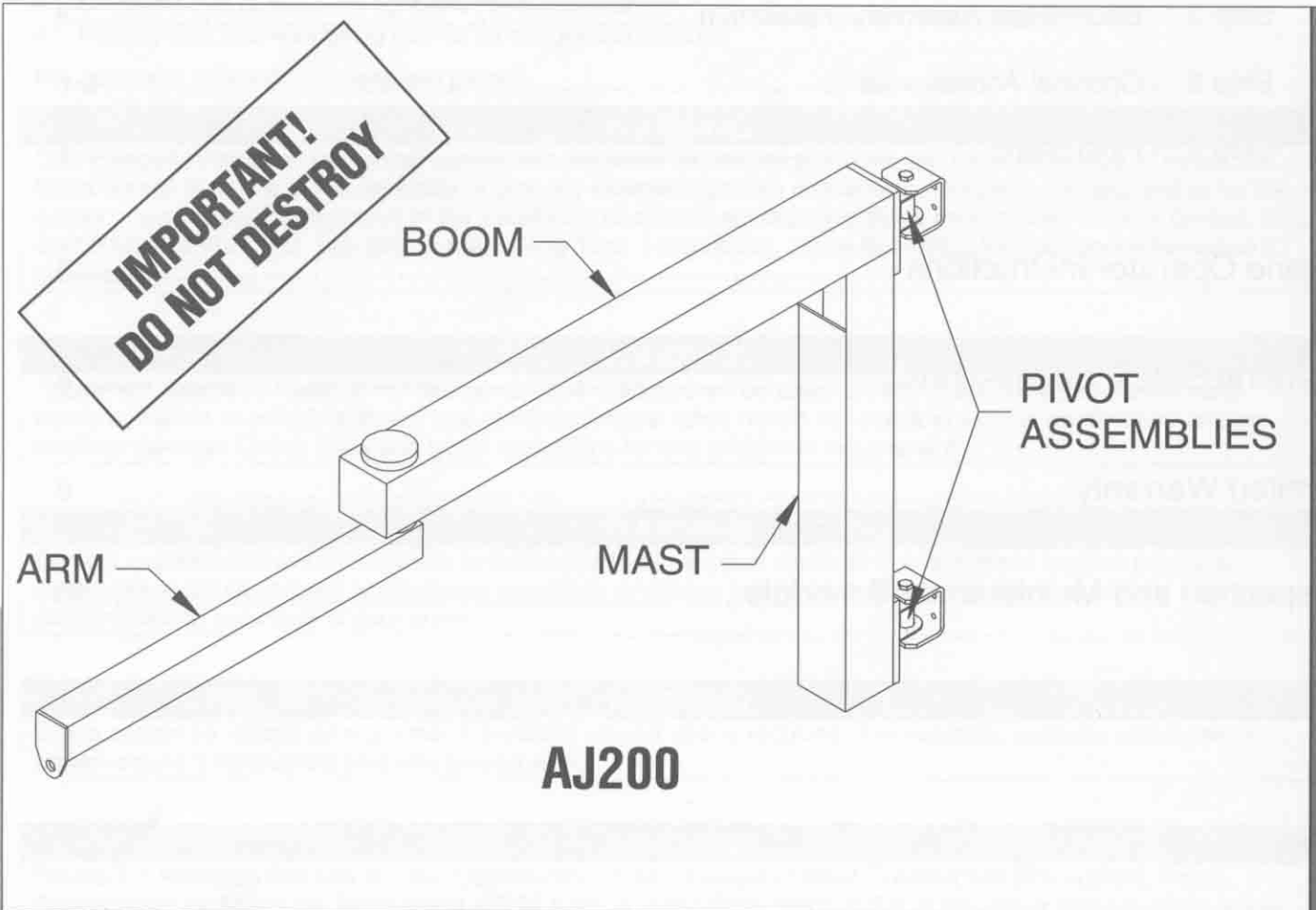

Wall Mounted Articulating Jib Crane

Gorbel Dealer _____

Gorbel Customer Order No. _____

Date _____

Month

Year

TABLE OF CONTENTS

Introduction	1
Installation	
Step 1 - Pre-assembly	2-3
Step 2 - Boom/Mast Assembly Installation	4
Step 3 - Optional Accessories	5-6
Step 4 - Final Steps	7
Crane Operator Instructions	8
General Safety Suggestions	8
Limited Warranty	9
Inspection and Maintenance Schedule	10

Questions? Concerns? Comments? Please call (800) 821-0086 (US and Canada) or (585) 924-6262 (outside US).

INTRODUCTION

Thank you for choosing a Gorbel® Articulating Jib Crane to solve your material handling needs. The innovative design and heavy-duty construction of Gorbel® Articulating Jib Cranes provide a superior quality product and offer years of long term value. The hoist and trolley weight allowance is 15% of the crane capacity (for example, a crane rated for 1000 pounds allows for a 1000-pound live load, plus 150 pounds for the weight of the hoist and trolley). There is also an allowance of 25% of the crane capacity for impact caused by the hoist use. Gorbel® Articulating Jib Cranes will provide many years of dependable service by following the installation and maintenance procedures described herein.

Dimensions contained in this installation manual are for reference only and may differ for your particular application. Please refer to the enclosed General Arrangement Drawing for the actual dimensions.

Normal safety precautions: These include, but are not limited to:

- Checking for obstructions in crane rotation
- Checking that all bolts are tight and have lockwashers
- Making sure that festooning cannot be snagged or pinched

For additional safety precautions see page 8.

WARNING

Only competent erection personnel familiar with standard fabrication practices should be employed to assemble these cranes because of the necessity of properly interpreting these instructions. Gorbel is not responsible for the quality of workmanship employed in the installation of a crane according to these instructions. Contact Gorbel, Inc., at 600 Fishers Run, P.O. Box 593, Fishers, New York 14453-0593, 1-800-821-0086, for additional information if necessary.

WARNING

Equipment described herein is not designed for, and should not be used for, lifting, supporting or transporting humans. Failure to comply with any one of the limitations noted herein can result in serious bodily injury and/or property damage. Check State and Local regulations for any additional requirements.

WARNING

Consult a qualified structural engineer to determine if your support structure is adequate to support the loads generated by thrust and pull (wall/column mounted), or anchor bolt force, over turning moment, or axial load (free standing/ceiling mounted) of your crane.

WARNING

Crane cannot be utilized as a ground: A separate ground wire is required. For example, systems with 3-phase power require 3 conductors plus one ground wire.

WARNING

Reference American Institute of Steel Construction (AISC) Manual of Steel Construction (9th edition), Part 5, Specification for Structural Joints using ASTM A325 or A490 Bolts (Section 8.d.2) for proper procedures to follow when using any torque tightening method.

WARNING

Do not field modify crane in any way. Any modifications without the written consent of Gorbel, Inc., will void warranty.

INSTALLATION

STEP 1 - PRE-ASSEMBLY

➡ **TIP:** Packing list can be found in plastic pocket attached to hardware box.

- 1.1 Read entire manual **before** beginning installation of crane.
- 1.2 Check packing list to ensure no parts have been lost prior to initializing assembly of crane.
- 1.3 Tools and materials (by others) often needed to assemble crane are as follows:
 - Torque wrench
 - Hand tools
 - Steel shims
 - Leveling tools and plumb bob
 - Lifting device to lift heavy masts and booms
 - Mounting hardware (grade 5 bolts or better)
- 1.4 Determine
 - Thrust and pull (**diagram 1A** and **chart 1A**, page 3)

WARNING

Consult a qualified structural engineer to determine that your support structure is adequate to support the loads generated by thrust and pull of your crane.

- Bracket centers (**diagram 1B** and **chart 1A**, page 3)
- Bolt pattern and dimensions (**diagram 1B** and **diagram 1C**, page 3, and **charts 1A and 1B**, page 3)

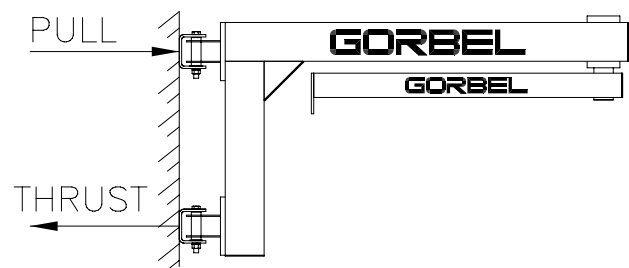

Diagram 1A. Thrust and pull definition.

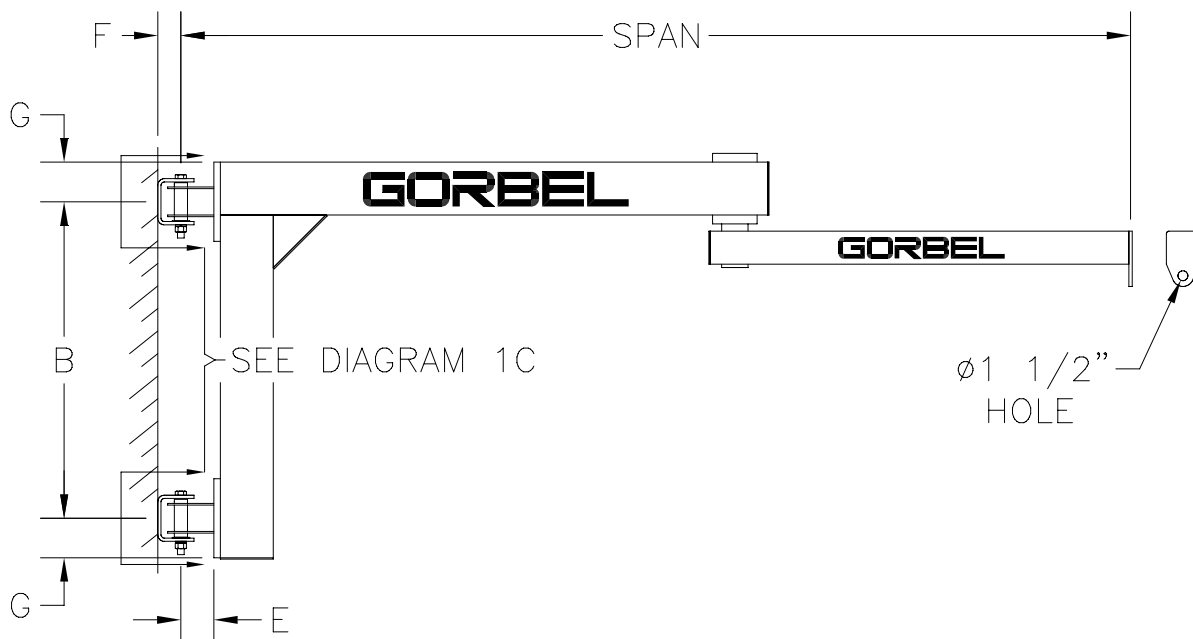

Diagram 1B.

STEP 1 - PRE-ASSEMBLY (CONTINUED)

CAPACITY	SPAN	B (in)	FITTING TYPE	THRUST & PULL
150#	8'	36	B1	715 #
	10'	36	B1	925 #
	12'	36	B1	905 #
	14'	48	B1	1,220 #
	16'	48	B1	1,451 #
250#	8'	36	B1	1,118 #
	10'	36	B1	1,537 #
	12'	48	B1	1,424 #
	14'	60	B1	1,368 #
	16'	60	B1	1,636 #
500#	8'	36	B1	2,137 #
	10'	48	B1	2,035 #
	12'	60	B1	2,050 #
	14'	60	B1	2,431 #
	16'	60	B2	3,074 #
1000#	8'	48	B1	3,056 #
	10'	48	B2	3,999 #
	12'	60	B2	3,886 #
	14'	60	B2	4,591 #
	16'	72	B2	4,647 #
2000#	8'	48	B2	5,975 #
	10'	60	B2	6,132 #
	12'	60	B2	7,549 #
	14'	72	B2	7,532 #
	16'	72	B2	8,688 #

Chart 1A.

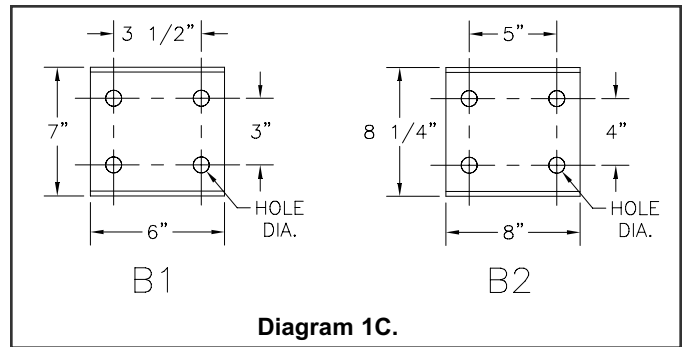

Diagram 1C.

BOLT PAT-TERN	E	F	G	HOLE DIA.	BOLT DIA.	BRACKET THICKNESS
B1	5"	3-1/2"	6"	11/16"	5/8"	1/2"
B2	5"	4"	6"	13/16"	3/4"	5/8"

All dimensions shown in inches.

Chart 1B.

STEP 2 - BOOM/MAST ASSEMBLY INSTALLATION

➔ **TIP:** Upper and lower formed channel (brackets) are identical.

STOP!

Do not proceed if your support structure does not meet the requirements identified in **Step 1.4**.

- 2.1 Determine position of **upper-formed** channel bracket on support structure. Drill bolt holes (see **chart 1B**, page 3, for bolt diameter) and bolt to support structure.
- 2.2 Determine position of lower formed channel bracket by measuring distance between bracket centers; clamp bracket to support structure. Align brackets by dropping plumb bob (by others) through pivot holes and making sure string is centered in pivot holes (**diagram 2A**). Shim as required.
- 2.3 Drill bolt holes for **lower** bracket (see **chart 1B**, page 3, for bolt diameter) and bolt to support structure. Tighten all mounting bolts (by others; bolts should be grade 5 or better) to manufacturer's specifications.
- 2.4 Attach boom/mast assembly to formed channel using hardware provided (**diagram 2B**). Be sure that thrust washers are in position. Tighten nuts on pivot bolt until lockwashers are compressed, being sure boom rotates freely.

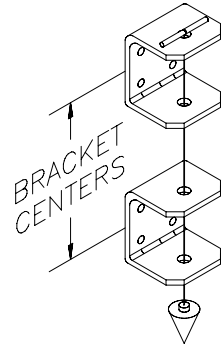

Diagram 2A.
Plumbing formed channel brackets.

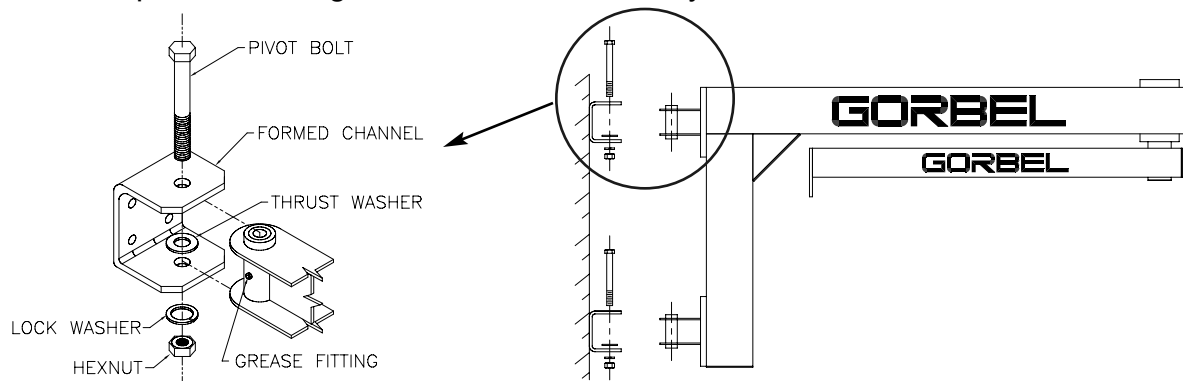

Diagram 2B. Attaching boom/mast assembly to formed channel.

- 2.5 Carefully swing crane through entire travel to ensure both boom/mast and arm are clear of obstructions.
- 2.6 Adjust the speed of rotation of the arm by adjusting the friction brake bolts located on the housing (**diagram 2C**). The 2 bolts going through the housing and pad should be tightened all the way down. The remaining 4 bolts should be tightened equally in a circular pattern until desired amount of resistance is achieved.

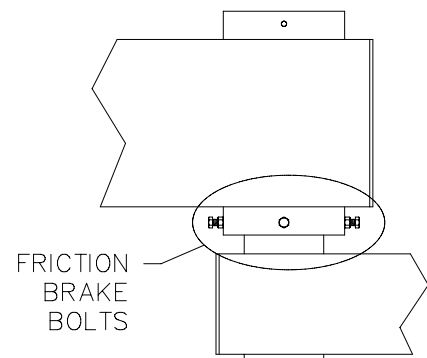

Diagram 2C. Friction brake bolt location.

WARNING

**DO NOT OVERTIGHTEN BOLTS:
OVERTIGHTENING BOLTS WILL RESULT
IN HIGHER ROTATIONAL PULL FORCES.**

STEP 3 - OPTIONAL ACCESSORIES

Arm Rotation Stop: (*diagram 3A*)

- A) Rotate arm to desired stopping position.
- B) Locate rotation stop assembly so rubber bumper engages boom tube at this point.
- C) Orient the rotation stop assembly on arm centerline as shown.
- D) Weld the rotation stop assembly to the arm tube using E70xx electrodes, per AWS D1.1 specifications.

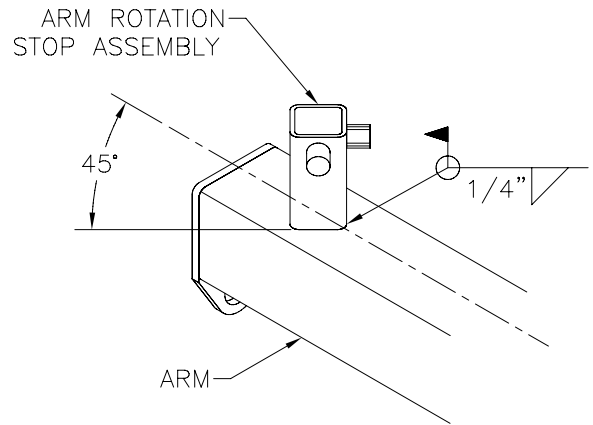

Diagram 3A. Welding arm rotation stop assembly.

Mast Rotation Stops: Both Formed Channels (*diagram 3B*)

- A) Swing boom to the farthest position of use on one side.
- B) Place rotation stop on upper-formed channel with its edge against the pivot assembly.
- C) Weld stop to formed channel using E70xx electrodes, per AWS D1.1 specifications.
- D) Repeat welding procedure for lower formed channel.
- E) Repeat Steps A-D for opposite direction.

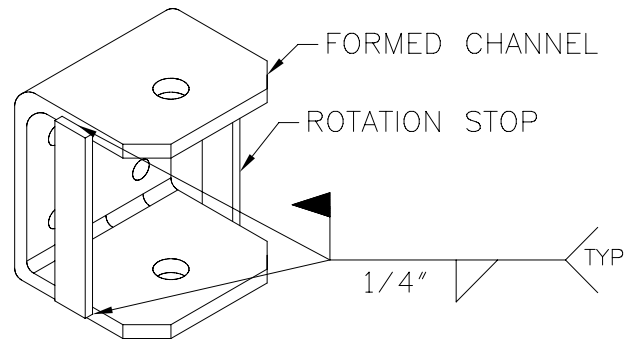

Diagram 3B. Welding mast rotation stops.

STEP 3 - OPTIONAL ACCESSORIES (CONTINUED)

Electrical Bottom Entry Collector - Arm (*diagram 3C*)

- A) Disassemble Collector Housing.
- B) Thread shaft stub onto shaft pipe.
- C) Attach four (4) loose wires to appropriate slip ring terminals and feed down through shaft pipe.
- D) Bolt bracket to collector using bolts that connect slip ring assembly to cover.
- E) Bolt bracket to boom using hardware provided.
- F) Thread conduit body onto shaft pipe.
- G) Use cord grip to secure round cable to conduit body, strip cable and connect to loose wires. Add gasket and cover to conduit body.
- H) Use cord grip to secure round cable to collector, strip cable and connect to appropriate terminals.
- I) Replace cover of collector housing.
- J) Attach J-boxes to end of arm and near mast pivot.
- K) Secure round cable in J-boxes using cord grips.
- L) Secure cable to crane using clamps provided.
- M) Connect lifting device to arm J-box.
- N) Connect power source to J-box near mast pivots.

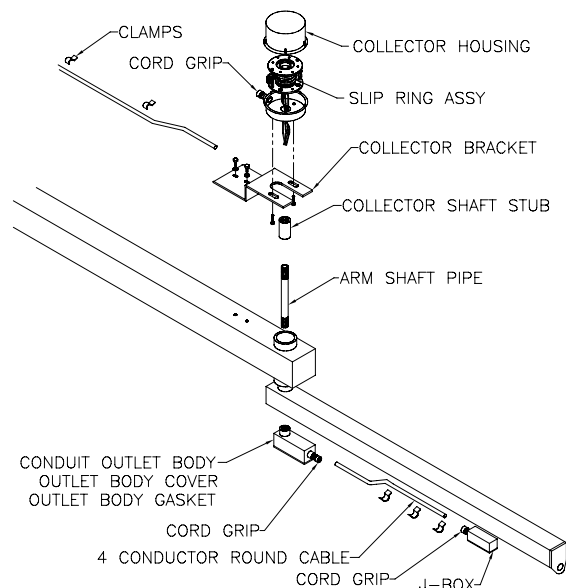

Diagram 3C. *Electrical bottom entry collector.*

Bottom Entry Air Swivel - Arm (*diagram 3D*)

- A) Connect male hose nipple, air swivel, coupling and shaft pipe.
- B) Connect elbow, arm pipe and female hose nipple.
- C) Bolt bracket to boom using hardware provided.
- D) Place the air swivel so that the slot in the top of the bracket captures the air swivel outlet.
- E) Thread elbow onto the end of the shaft pipe and clamp arm pipe into place.
- F) Connect air hose to nipples and secure with worm gear clamps.
- G) Secure air hose to crane using clamps provided.
- H) Connect air hose to lifting device and air supply.

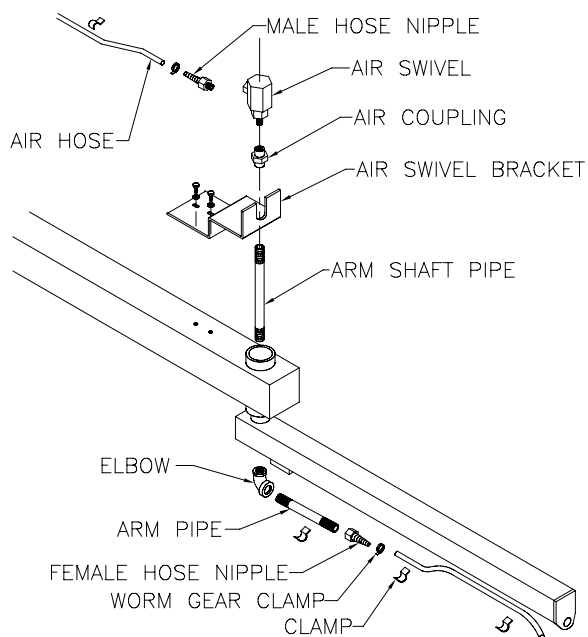

Diagram 3D. *Bottom entry air-swivel assembly.*

STEP 4 - FINAL STEPS

➡ **TIP:** Do not throw away this manual: maintenance schedule is located on the back cover.

- 4.1 Check to make sure all bolts are tight and lockwashers are compressed.
- 4.2 Check rotation of both boom and arm. Adjust arm rotation using friction brakes located in housing by tightening or loosening bolts as often as needed.

WARNING

DO NOT OVERTIGHTEN BOLTS: OVERTIGHTENING BOLTS WILL RESULT IN HIGHER ROTATIONAL PULL FORCES.

- 4.3 Grease both pivot assemblies (use Lubriplate #630-AA or equivalent).
- 4.4 If necessary, touch up crane with paint provided.
- 4.5 Keep Packing List, Installation Manual, General Arrangement Drawing and any other inserts filed together in safe place.

CRANE OPERATOR INSTRUCTIONS

Overhead cranes and jib cranes generally handle materials over working areas where there are personnel. Therefore, it is important for the Crane Operator to be instructed in the use of the crane and to handle the severe consequences of careless operation.

It is not intended that these suggestions take precedence over existing plant safety rules and regulations or OSHA regulations. However, a thorough study of the following information should provide a better understanding of safe operation and afford a greater margin of safety for people and machinery on the plant floor.

It must be recognized that these are suggestions for the Crane Operator's use. It is the responsibility of the owner to make personnel aware of all federal, state and local rules and codes, and to make certain operators are properly trained.

Qualifications

Crane operation, to be safe and efficient, requires skill: the exercise of extreme care and good judgment, alertness and concentration, and rigid adherence to proven safety rules and practices as outlined in applicable and current ANSI and OSHA safety standards. In general practice, no person should be permitted to operate a crane:

- Who cannot speak the appropriate language or read and understand the printed instructions.
- Who is not of legal age to operate this type of equipment.
- Whose hearing or eyesight is impaired (unless suitably corrected with good depth perception).
- Who may be suffering from heart or other ailments which might interfere with the operator's safe performance.
- Unless the operator has carefully read and studied this operation manual.
- Unless the operator has been properly instructed.
- Unless the operator has demonstrated his instructions through practical operation.
- Unless the operator is familiar with hitching equipment and safe hitching equipment practices.

Handling the Jib Boom Motion

Before using the boom of the jib crane, the operator should be sure the hook is high enough to clear any obstruction. Before a load is handled by the crane, the jib boom should be brought into position so that it is directly over the load. Start the jib boom slowly and bring it up to speed gradually. Approaching the place where it is desired to stop the jib, reduce the boom speed.

Handling the Trolley Motion

Before a load is handled, the hoist should be positioned directly over the load that is to be handled. When the slack is taken out of the slings, if the hoist is not directly over the load, bring it directly over the load before hoisting is continued. Failure to center the hoist over the load may cause the load to swing upon lifting. Always start the trolley motion slowly and reduce the trolley speed gradually.

Handling the Hoist Motion

Refer to the lifting (hoist) equipment's operating instructions.

GENERAL SUGGESTIONS

Know Your Crane

Crane operators should be familiar with the principal parts of a crane and have a thorough knowledge of crane control functions and movements. The crane operator should be required to know the location and proper operation of the main conductor disconnecting means for all power to the attachments on the crane.

Responsibility

Each crane operator should be held directly responsible for the safe operation of the crane. Whenever there is any doubt as to SAFETY, the crane operator should stop the crane and refuse to handle loads until: (1) safety has been assured or (2) the operator has been ordered to proceed by the supervisor, who then assumes all responsibility for the SAFETY of the lift.

Do not permit **ANYONE** to ride on the hook or a load.

Inspection

Test the crane movement and any attachments on the crane at the beginning of each shift. Whenever the operator finds anything wrong or apparently wrong, the problem should be reported immediately to the proper supervisor and appropriate corrective action taken.

Operating Suggestions

One measure of a good crane operator is the smoothness of the crane operation. The good crane operator should know and follow these proven suggestions for safe, efficient crane handling.

1. The crane should be moved smoothly and gradually to avoid abrupt, jerky movements of the load. Slack must be removed from the sling and hoisting ropes before the load is lifted.
2. Center the crane over the load before starting the hoist to avoid swinging the load as the lift is started. Loads should not be swung by the crane to reach areas not under the crane.
3. Crane-hoisting ropes should be kept vertical. Cranes shall not be used for side pulls.
4. Be sure everyone in the immediate area is clear of the load and aware that a load is being moved.
5. Do not make lifts beyond the rated load capacity of the crane, sling chains, rope slings, etc.
6. Make certain that before moving the load, load slings, load chains, or other lifting devices are fully seated in the saddle of the hook with hook latch closed (if equipped with hook latch).
7. Check to be sure that the load and/or bottom block is lifted high enough to clear all obstructions when moving boom or trolley.
8. At no time should a load be left suspended from the crane unless the operator has the push button with the power on, and under this condition keep the load as close as possible to the floor to minimize the possibility of an injury if the load should drop. When the crane is holding a load, the crane operator should remain at the push button.
9. Do not lift loads with sling hooks hanging loose. If all slings hooks are not needed, they should be properly stored, or use a different sling.
10. All slings or cables should be removed from the crane hooks when not in use (dangling cables or hooks hung in sling rings can inadvertently snag other objects when the crane is moving).
11. Operators shall not carry loads and/or empty bottom blocks over personnel. Particular additional caution should be practiced when using magnet or vacuum devices. Loads, or parts of loads, held magnetically could drop. Failure of power to magnets or vacuum devices can result in dropping the load. Extra precaution should be exercised when handling molten metal in the proximity of personnel.
12. Whenever the operator leaves the crane the following procedures should be followed.
 - Raise all hooks to an intermediate position.
 - Spot the crane at an approved designated location.
 - Place all controls in the "off" position.
 - Open the main switch to the "off" position.
 - Make visual check before leaving the crane.
13. In case of emergency or during inspection, repairing, cleaning or lubrication, a warning sign or signal should be displayed and the main switch should be locked in the "off" position. This should be done whether the work is being done by the crane operator or by others.
14. Contact with rotation stops or trolley end stops shall be made with extreme caution. The operator should do so with particular care for the safety of persons below the crane, and only after making certain that any persons on the other cranes are aware of what is being done.
15. ANY SAFETY FEATURES AND MECHANISMS BUILT-IN OR OTHERWISE PROVIDED WITH THE CRANE BY GORBEL ARE REQUIRED FOR THE SAFE OPERATION OF THE CRANE. DO NOT, UNDER ANY CIRCUMSTANCES, REMOVE OR OTHERWISE IMPAIR OR DISABLE THE PROPER FUNCTIONING OF ANY CRANE SAFETY MECHANISMS OR FEATURES BUILT-IN OR OTHERWISE PROVIDED BY GORBEL FOR SAFE OPERATION OF THE CRANE. ANY REMOVAL, IMPAIRMENT OR DISABLING OF ANY SUCH SAFETY MECHANISMS OR FEATURES OR OTHER USE OR OPERATION OF THE CRANE WITHOUT THE COMPLETE AND PROPER FUNCTIONING OF ANY SUCH SAFETY MECHANISMS OR FEATURES AUTOMATICALLY AND IMMEDIATELY VOIDS ANY AND ALL EXPRESS AND IMPLIED WARRANTIES OF ANY KIND OR NATURE.

LIMITED WARRANTY

It is agreed that the equipment purchased hereunder is subject to the following LIMITED warranty and no other. Gorbel Incorporated ("Gorbel"), warrants the manual push-pull Work Station Cranes, Jib Crane, and Gantry Crane products to be free from defects in material or workmanship for a period of five years or 10,000 hours use from date of shipment. Gorbel warrants the Motorized Work Station Cranes and Jib Crane products to be free from defects in material or workmanship for a period of two years or 4,000 hours use from the date of shipment. Gorbel warrants the G-Force® and Easy Arm™ products to be free from defects in material or workmanship for a period of one year or 2,000 hours use from the date of shipment. This warranty shall not cover failure or defective operation caused by operation in excess of recommended capacities, misuses, negligence or accident, and alteration or repair not authorized by Gorbel. No system shall be field modified after manufacture without the written authorization of Gorbel, Inc. Any field modification made to the system without the written authorization of Gorbel, Inc. shall void Gorbel's warranty obligation. OTHER THAN AS SET FORTH HEREIN, NO OTHER EXPRESS WARRANTIES, AND NO IMPLIED WARRANTIES, ORAL OR WRITTEN, INCLUDING BUT NOT LIMITED TO THE WARRANTIES OF MERCHANTABILITY OR FITNESS FOR A PARTICULAR PURPOSE, ARE MADE BY GORBEL WITH RESPECT TO ITS PRODUCTS AND ALL SUCH WARRANTIES ARE HEREBY SPECIFICALLY DISCLAIMED. GORBEL SHALL NOT BE LIABLE UNDER ANY CIRCUMSTANCES FOR ANY INCIDENTAL, SPECIAL AND/OR CONSEQUENTIAL DAMAGES WHATSOEVER, WHETHER OR NOT FORESEEABLE, INCLUDING BUT NOT LIMITED TO DAMAGES FOR LOST PROFITS AND ALL SUCH INCIDENTAL, SPECIAL AND/OR CONSEQUENTIAL DAMAGES ARE HEREBY ALSO SPECIFICALLY DISCLAIMED. Gorbel's obligation and Purchaser's or end user's sole remedy under this warranty is limited to the replacement or repair of Gorbel's products at the factory, or at the discretion of Gorbel, at a location designated by Gorbel. Purchaser or end user shall be solely responsible for all freight and transportation costs incurred in connection with any warranty work provided by Gorbel hereunder. Gorbel will not be liable for any loss, injury or damage to persons or property, nor for damages of any kind resulting from failure or defective operation of any materials or equipment furnished hereunder. Components and accessories not manufactured by Gorbel are not included in this warranty. Purchaser's or end user's remedy for components and accessories not manufactured by Gorbel is limited to and determined by the terms and conditions of the warranty provided by the respective manufacturers of such components and accessories.

A) DISCLAIMER OF IMPLIED WARRANTY OF MERCHANTABILITY

Gorbel and Purchaser agree that the implied warranty of merchantability is excluded from this transaction and shall not apply to the goods involved in this transaction.

B) DISCLAIMER OF IMPLIED WARRANTY OF FITNESS FOR PARTICULAR PURPOSE

Gorbel and Purchaser agree that the implied warranty of fitness for particular purpose is excluded from this transaction and shall not apply to the goods involved in this transaction.

C) DISCLAIMER OF EXPRESS WARRANTY

Gorbel's agents, or dealer's agents, or distributor's agents may have made oral statements about the machinery and equipment described in this transaction. Such statements do not constitute warranties, and Purchaser agrees not to rely on such statements. Purchaser also agrees that such statements are not part of this transaction.

D) DISCLAIMER OF SPECIAL, INCIDENTAL AND CONSEQUENTIAL DAMAGES

Gorbel and Purchaser agree that any claim made by Purchaser which is inconsistent with Gorbel's obligations and the warranty remedies provided with Gorbel's products, and in particular, special, incidental and consequential damages, are expressly excluded.

E) DEALER OR DISTRIBUTOR NOT AN AGENT

Gorbel and Purchaser agree that Purchaser has been put on notice that dealer or distributor is not Gorbel's agent in any respect for any reason. Gorbel and Purchaser also agree that Purchaser has been put on notice that dealer or distributor is not authorized to incur any obligations or to make any representations or warranties on Gorbel's behalf other than those specifically set forth in Gorbel's warranty provided in connection with its product.

F) MERGER

This warranty agreement constitutes a final and complete written expression of all the terms and conditions of this warranty and is a complete and exclusive statement of those terms.

G) PAINTING

Every crane (excluding components) receives a quality paint job before leaving the factory. Unfortunately, no paint will protect against the abuses received during the transportation process via common carrier. We have included at least one (1) twelve ounce spray can for touchup with each crane ordered (unless special paint was specified). If additional paint is required, contact a Gorbel® Customer Service Representative at 1-800-821-0086 or 1-585-924-6262.

Title and Ownership:

Title to the machinery and equipment described in the foregoing proposal shall remain with the Gorbel and shall not pass to the Purchaser until the full amount herein agreed to be paid has been fully paid in cash.

Claims and Damages:

Unless expressly stated in writing, goods and equipment shall be at Purchaser's risk on and after Seller's delivery in good shipping order to the Carrier. Gorbel shall in no event be held responsible for materials furnished or work performed by any person other than it or its authorized representative or agent.

Cancellations:

If it becomes necessary for the purchaser to cancel this order wholly or in part, he shall at once so advise Gorbel in writing. Upon receipt of such written notice all work will stop immediately. If the order entails only stock items, a flat restocking charge of 15% of the purchase price will become due and payable by Purchaser to Gorbel. Items purchased specifically for the canceled order shall be charged for in accordance with the cancellation charges of our supplier plus 15% for handling in our factory. The cost of material and/or labor expended in general fabrication for the order shall be charged for on the basis of total costs to Gorbel up to the time of cancellation plus 15%.

Returns:

No equipment, materials or parts may be returned to Gorbel without express permission in writing to do so.

Extra Charge Delay: If Purchaser delays or interrupts progress of Seller's performance, or causes changes to be made, Purchaser agrees to reimburse Gorbel for expense, if any, incident to such delay.

Changes and Alterations:

Gorbel reserves the right to make changes in the details of construction of the equipment, as in its judgment, will be in the interest of the Purchaser; will make any changes in or additions to the equipment which may be agreed upon in writing by the Purchaser; and Gorbel is not obligated to make such changes in products previously sold any customer.

Third Party Action:

Should Gorbel have to resort to third party action to collect any amount due after there (30) days from date of invoice, the Purchaser agrees to pay collection costs, reasonable attorney's fees, court costs and legal interest.

OSHA Responsibilities:

Gorbel agrees to fully cooperate with Purchaser in the design, manufacture or procurement of safety features or devices that comply with OSHA regulations. In the event additional equipment or labor shall be furnished by Gorbel, it will be at prices and standard rates then in effect, or as may be mutually agreed upon at the time of the additional installation.

Equal Employment Opportunity:

Gorbel agrees to take affirmative action to ensure equal employment opportunity for all job applicants and employees without regard to race, color, age, religion, sex, national origin, handicap, veteran, or marital status. Gorbel agrees to maintain non-segregated work facilities and comply to rules and regulations of the Secretary of Labor or as otherwise provided by law or Executive Order.

INSPECTION AND MAINTENANCE SCHEDULE

GORBEL® ARTICULATED JIB CRANE INSPECTION AND MAINTENANCE SCHEDULE			
ITEM	COMPONENT	MAINTENANCE	FREQUENCY*
1	Mounting Bolts	Check that lockwashers are compressed and nuts tightened to manufacturer's specifications.	Every 500 hours or 3 months
2	Pivot Assemblies	Check that lockwashers are compressed. Check for wear on thrust washers. Grease fittings (use Lubriplate #630-AA or equivalent).	Every 1000 hours or 6 months
3	Friction Brakes	Be sure pressure on brakes is properly adjusted. Check for excessive wear (thinning of nylon pad).	Every 1000 hours or 6 months
4	Accessory Items	Conduct a general inspection of all accessory items.	Every 1000 hours or 6 months
5	Gorbel® Crane	Conduct a visual inspection of crane overall.	Every 1000 hours or 6 months

*Federal, state and local codes may require inspection and maintenance checks more often. Please check the federal, state and local code manuals in your area.

WARNING

Any changes in rotation effort or unusual noises must be immediately identified and corrected.

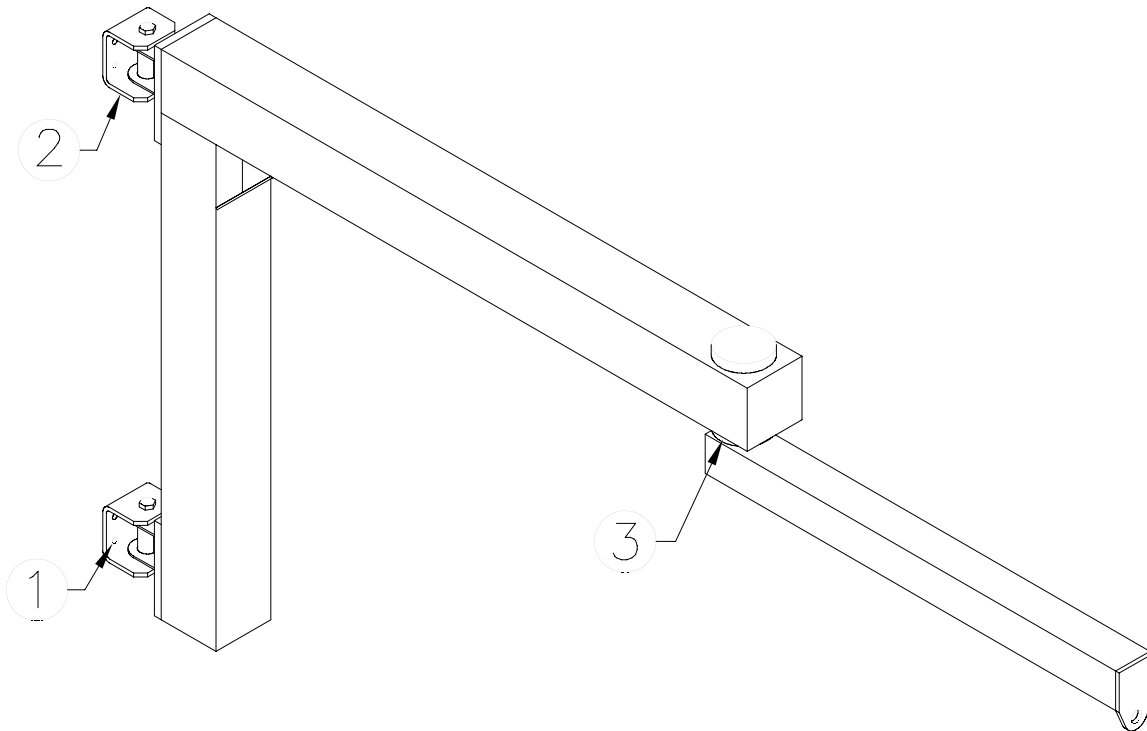

GORBEL®

600 Fishers Run, P.O. Box 593
 Fishers, NY 14453-0593
 Telephone: (800) 821-0086
 (585) 924-6262
 Fax: (800) 828-1808
 E-Mail: info@gorbel.com
<http://www.gorbel.com>

© 2005 Gorbel Inc.
 All Rights Reserved